

# BISON

## REFRIGERATION

Units Manufactured Prior 10-1-18

Include 1 Year Parts + Labor / 5 Year Compressor Warranty

Units Manufactured After 10-1-18

Include 2 Year Parts + Labor / 5 Year Compressor Warranty

### BST-72-30 3 Door Sandwich Unit

#### Dimensions

Exterior Dimensions (Inches)	72.75" x 34" x 47.25"
Interior Dimensions Top (Inches)	67.55" x 20.5" x 10"
Interior Dimensions Bottom (Inches)	69" x 24" x 28"
Packaging Dimensions (Inches)	75.4" x 37.5" x 48.2"
Capacity (cu. ft.)	22.6 cu. ft.
Gross Weight (lbs)	397 lbs

#### Construction

Exterior Material	430 series stainless steel
Interior Material	304 series stainless steel
Insulation Material	Polyurethane
Insulation Thickness (mm)	45
# of Doors	3
# of Shelves	3
Shelf Material	Plastic coated steel
Shelf Load Capacity (lbs/pc)	155 lbs

\*Does not include pans

#### Cooling

Temperature Range	33° ~ 40° F
Refrigerant	R-134A
Refrigerant Amount (oz)	17.6
Maximum Ambient Temperature Rating	100.4° F
Defrost Method	Air Defrost
Defrost Power (W)	0
Cooling Method	Ventilated
Temperature Controller	Thermostat
Compressor H/P	1/2

#### Electrical

Voltage (v/Hz)	115/60
Power (W)	630
Power Consumption (kw/24hr)	2.6
Phase	1

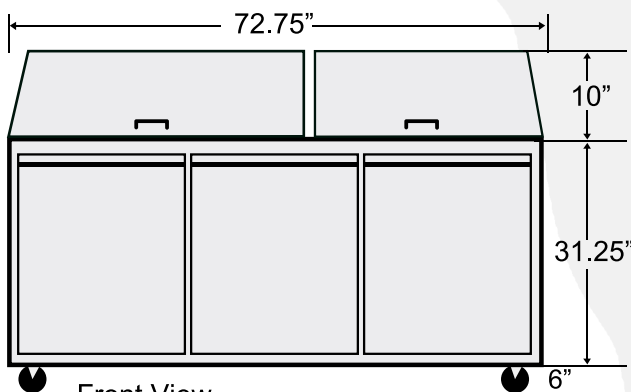

Front View

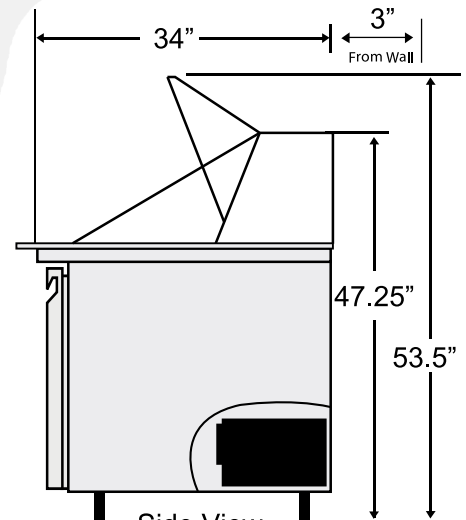

Side View

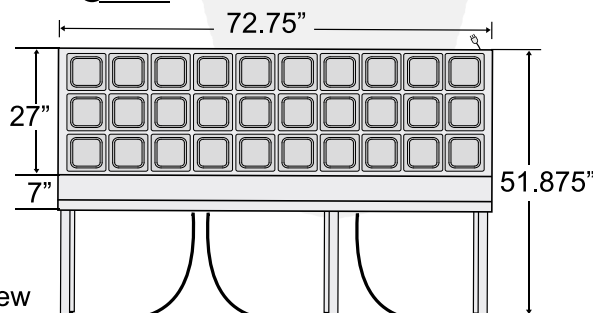

Top View

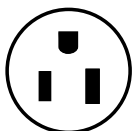

NEMA 5-15P

